

ALUNAUTIC
Powered by Euro Offshore BV



eo
Euro Offshore.com

Alunautic

Powered by Euro Offshore BV

Alunautic is a brand of the Dutch company Euro Offshore B.V. which designs, builds and distributes aluminum boats for the professional offshore market.

At Euro Offshore B.V. we have over 20 years of experience in building sport boats, workboats, RIB's and landingcrafts. All Alunautic boats are built according to the latest CE regulations and all aluminum used for construction is of the Marine grade alloy.

The Dutch craftsmanship at Alunautic means that we only produce the highest quality vessels with excellent sailing characteristics. Everyone in our company is passionate about our products.

If you require more detailed information about our Alunautic boats please visit our website, or visit our factory to take one for a test run!

We are looking forward seeing you!

With kind regards,



Herman Vroege
Director

Alunautic

Beatrixhaven 19, 4251 NK, Werkendam,
The Netherlands, +31(0) 183 69 10 10,
info@eurooffshore.com, www.alunauticboats.com



Euro Offshore

Facilities

BEATRIXHAVEN	
←	Beerens BV 11
←	Instalho BV 13
←	Van Wijk Stuurhuizen 3b
BEATRIXHAVEN	
→	Clean BV 25a
→	Hoogendoorn mbi 35
→	IMS-Werkendam BV 25b
→	Transito Bevrachting BV 43
→	v.d. Bergh&Co Produktie 27

Main office and worldwide distributors

The headquarters and factory of Euro Offshore BV is based in Werkendam in the Netherlands.

Our main office and factory Euro Offshore BV is based in Werkendam in the south of the Netherlands, approximately 1 hour drive from Amsterdam international airport (Schiphol).

Our yard facilities in the Netherlands include the main office with sales, service, design & engineering and backoffice, a workshop over 2000m² with an inhouse aluminium welding facility, assembly department and sailmakershop.



Our company has gained an excellent reputation for quality design and construction at reasonable prices. It is generally accepted as one of the premier aluminum builder of small (15' to 46') boats in The Netherlands.

In recent years we built between 6 and 10 boats per year, depending on size and complexity. Increasing the volume of business, though desirable in some respects, is not a high priority. Our objective is to do an excellent job of design and construction on boats for exacting needs. Our boatbuilding operation has spawned an increasing amount of fabrication work, particularly marine accessories.



Why Alunautic?

Five reasons why we think Alunautic is the best partner for the fishing-, fire fighting-, offshore-, and pleasure market boaters.

- Competitive pricing, Alunautic stands for the best design for the best price in this market.
- Made in Holland, "Dutch craftsmanship" is the catchphrase of this product.
- Material, the aluminum for the Alunautic boats has the Marine Qualification (Din).
- Qualification, Alunautic boats have been qualified according to the latest CE regulations.
- Custom built, EO has the craftsmanship to design and build boats on client request.

Why Aluminum?

A welded aluminum hull, as compared to fiberglass, will yield a more durable, longer lived boat which can be easily customized to customer requirements. Is simply and quickly repaired and is easily retrofitted to meet changing operating requirements.

General

Aluminum is a good choice for boats in the 6 to 20 meter range. Aluminum is used for most small to medium sized commercial fishing boats. and it is used in most crew -workboats in the USA and Gulf of Mexico. Aluminum has also been accepted as a perfect material for sea going RIB'S.

A lot of boats up to 20 meters are built of aluminum alloys. Small, thin hulled boats are fastened with rivets, with some welding on thick sections. Aluminum boats plated with 1 mm or thicker material, such as that proposed, are "fastened" using the metal inert gas (MIG) welding process. Aluminum has a higher strength to weight ratio than most other boat building materials. Aluminum has exceptional dent resistance and aluminum boats have typically 30 to 40% less weight than their fiberglass counterparts and 45 to 55% less than their steel counter parts. Weight savings provide a number of performance bonuses. For example, in a given size and shape of boat, lighter weight means greater speed with the same horsepower, reduced fuel consumption with the same speed, or a greater payload - more cargo or more range - all meaningful advantages. Light weight also provides reduced draft for a given payload.

Alunautic

Powered by Euro Offshore B.V.

Durability and repairability

Aluminum has great toughness. It will survive impacts that neither steel nor fiberglass will survive. In such cases the steel or fiberglass will rupture, while aluminum will merely dent. Like steel, aluminum has considerable ductility, i.e. the ability to withstand permanent deformation without rupture.

It has one third the modulus of elasticity of steel, thus it absorbs the energy of any impact over a greater distance than steel. Stress levels therefore are considerably less than would be the case in steel. Fiberglass, on the other hand, is extremely brittle and is thus subject to cracking and fracture during impact. Aluminum boats are much easier to repair than fiberglass boats, particularly fiberglass boats with foam liners. With aluminum, dents can often be pounded out with a hammer, but if necessary, sections of a plate can be cut out with a saw and simply replaced.

Flammability

Aluminum does not burn. Fiberglass boats contain petroleum based resins which burn energetically. Fire retardant resin makes them harder to "light", but nonetheless the burning is energetic once started.

Ease of Customization

Since aluminum boats are not built from moulds as are fiberglass boats, changes in design, modification in the location of bulkheads, size of cabins, etc. are all accomplished much more readily than with fiberglass. The ease with which equipment can be relocated by cutting and welding or drilling and bolting is also advantageous. With the advent of computer aided design, custom hull shapes and arrangements can be provided at prices which are competitive with low volume production runs.

Corrosion resistance

The salt water corrosion resistance of Aluminum is excellent and has been demonstrated by the Aluminum Company of America (ALCOA) in a thirty year test from the mid 1930's to the mid 1960's at which time a section of an aluminum hull was retired from its test site in Narragansett Bay because so little was happening to it. Corrosion problems with aluminum boats can usually be traced to either the use of improper alloys, galvanic or electrolytic corrosion, all of which may be easily eliminated through proper material selection, proper wiring, bonding and isolation procedures.





Alunautic

Products

At Alunautic we build different types of aluminium boats, each one specially designed for its own use. Whether you need a sportboat, workboat, landingcraft - catamaran, RIB, or a custom build boat, at Alunautic we build high quality aluminium boats according to the latest requirements and CE regulations. Each type of boat is build in several lenghts with different options to suit the clients wishes.

The Alunautic range contains:

- Landingcrafts - catamarans
- Aluminium RIB's
- Sport boats
- Work boats

Due to our extensive experience in boat building we also build custom made boats according to our client's requests.

Alunautic offers the best designs and prices for all companies like the yachting, navy, dredging, rescue, offshore and many more.



Landingcrafts - catamarans

All Alunautic landingcrafts - catamarans are build in a one or two hull type way. Our landing crafts - catamarans are among the safest boats in their class because of the separate foam filled compartments, anti-slide- and self bailing decks.

The Alunautic landingcrafts - catamarans are available in 7 standard models with lengths of 4.50, 5.50, 6.20, 7.00, 8.50, 10.50, 12.50 and 15.50 meters. All custom solutions up to your request.



Aluminium RIB's

The Alunautic RIB's are build with a deep V-shaped hull for outstanding performances at high speeds. Our RIB's are among the safest boats in their class because of the EOS foam system in the hull for extra buoyancy and the anti-slide- and self bailing decks.

The Alunautic Ribs are produced in 5 standard lengths of 7.00, 8.00, 9.00, 10.00, 11.00 and 12.00 meters and have many extra options. All custom solutions up to your request.



Sportboats

The Alunautic Sportboats are made of aluminum with a deep V-hull shape, suitable for inshore shipping. Our Sportboats are among the safest boats in their class because of the 2 x 2 separate foam filled compartments, anti-slide- and self bailing decks. Our Sport boats are standard equipped with anchor compartment including hatch, 2 bollards and hoisting points.

The Alunautic Sport boats are available in several lengths starting from 4.5 meter up to custom builds to clients request.



Workboats

The Alunautic Work boats are made of aluminum with a deep V-hull shape, suitable for inshore shipping. Our Work boats are among the safest boats in their class because of the 2 x 2 separate foam filled compartments, anti-slide- and self bailing decks. Our Work boats are standard equipped with anchor compartment including hatch, 2 bollards and hoisting points.

The Alunautic Work boats are available in several lengths starting from 4.5 meter up to custom builds to clients request.



Alunautic Landingcrafts - catamarans

The Alunautic landingcrafts - catamarans are great boats for a wide range of purposes. Due to the the lightweight construction these boats are fast and also very stable. The flat bottom hull shape creates lots of landing opportunities.

All Alunautic landingcrafts - catamarans are build in a one or two hull type way. Our landing crafts - catamarans are among the safest boats in their class because of the separate foam filled compartments, anti-slide- and self bailing decks.

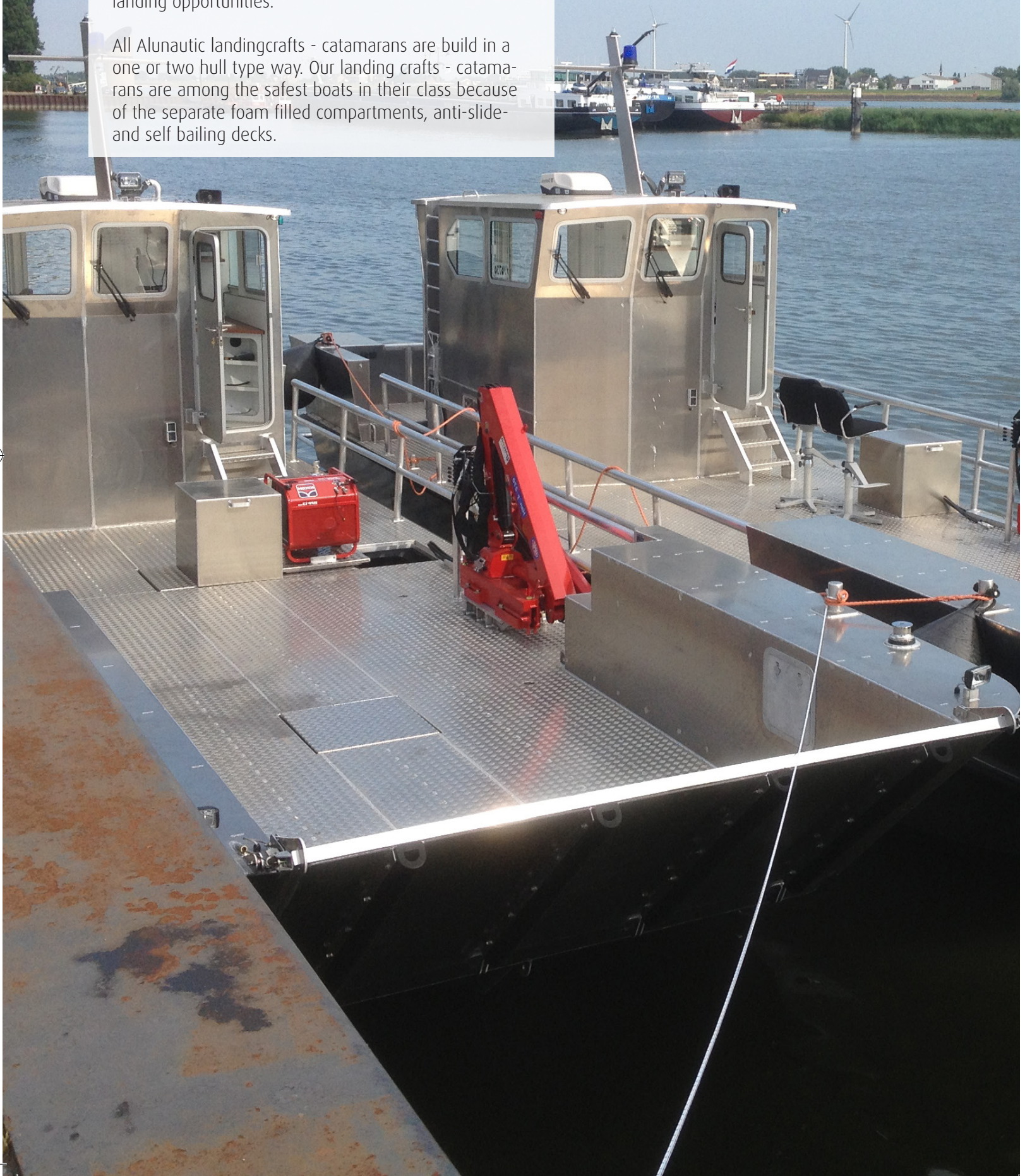

Alunautic landingcrafts - catamarans

The Alunautic landingcrafts - catamarans are available in various standard models with lengths of 4.50, 5.50, 6.20, 7.50, 8.50, 10.00, 12.50 and 15.50 meters. All Alunautic landingcrafts - catamarans are build in a one or two hull type way, depending on the size of the boat. The engine options for the landingcrafts - catamarans are outboard or inboard with the option for sterndrive or waterjet propulsion. All custom solutions up to your request.



Type	Length x beam (m)	Draft (m)	Max hp	Deadrise at transom	Classification
4.80	4.48 x 1.77	0.30 - 0.40	15 - 50	12 °	CE C
5.50	5.48 x 2.44	0.30 - 0.40	40 - 150	12 °	CE C
6.20	6.21 x 2.11	0.30 - 0.40	40 - 250	15 °	CE C
7.50	7.67 x 2.60	0.30 - 0.40	40 - 400	15 °	CE C-B
8.50	8.51 x 2.84	0.32 - 0.56	70 - 500	15 °	CE C-B
10.00	9.76 x 3.17	0.39 - 0.74	100 - 500	15 °	CE C-B
12.50	12.50 x 3.60	0.50 - 0.80	100 - 1000	17 °	CE C-B
15.50	15.50 x 4.35	0.50 - 0.80	100 - 1000	17 °	CE C-B

Standard equipment:

- EOS foam system for extra buoyancy
- Hoisting points
- Anchor compartment including hatch
- Bilge outlets
- 1 bollard



Option package:

- D-Fender (rubber)
- Steering console
- Steering system (hydraulic/mechanic)
- Cabin
- Leaning post
- Side seats
- Lifting sling
- Boat cover
- Anchor (line)
- Mooring lines
- Aluminum railing
- Towing pole
- Fire extinguisher
- Professional electrical installation IP67
- Masthead light
- Navigation light
- Horn

Alunautic RIB's

The Alunautic RIB's designed and produced by Euro Offshore BV are available in several lengths and have a deep V-shaped hull for outstanding performances at high speeds. Due to the EOS foam system in the hull of the RIB's, they have excellent buoyancy. Our aluminium RIB's are among the safest in their class, because of the antislip- and self bailing decks.

The Alunautic RIB's are produced in several standard lengths from 4.00 till 14.00 meters. Any tailor made solutions can be provided by the EO design department to build a custom built boat to suit your needs.



Alunautic RIB's

The Alunautic RIB's are available with an in - or outboard type of engine. The inboard version can be equipped with an aft or centre mounted engine, the propulsion options for the Alunautic RIB's are either sterndrive or waterjet.



Type	Length	Draft	Max hp	Hull deadrise	Classification
4.00	4.04 x 1.78	0.33	15 - 50	17 °	CE C
6.00	6.00 x 2.50	0.50	40 - 150	23 °	CE B
7.50	7.44 x 2.85	0.50	40 - 400	23 °	CE B
8.00	8.50 x 3.00	0.50	40 - 600	23 °	CE B
9.00	9.00 x 3.00	0.50	40 - 900	23 °	CE B
10.00	10.20 x 3.40	0.60	40 - 900	23 °	CE B
11.00	11.20 x 3.40	0.60	40 - 1000	23 °	CE B
13.00	13.03 (hull 11.85) x 4.10	0.65	40 - 1000	26 °	CE B / Lloyds

Standard equipment:

- EOS fender system (Inflatable or PU foam)
- EOS foam system for extra buoyancy
- Hoisting points
- Anchor compartment incl. hatch
- Bilge outlets
- 1 bollard



Option package:

- Steering console
- Steering system (hydraulic/mechanic)
- Cabin
- Leaning post
- Side seats
- Lifting sling
- Boat cover
- Anchor (line)
- Mooring line
- Foam filled fender
- Hypalon-neoprene fender
- Aluminum railing
- Towing pole
- Fire extinguisher
- Professional electrical installation IP67
- Masthead light
- Navigation light
- Horn

Alunautic Sport boats

The Alunautic Sport boats lines are available in several lengths and custom builds. Our Sport boats are made of aluminum with a deep V-hull shape, suitable for inshore shipping. Because of their 2 x 2 separate foam filled compartments, these aluminium Sport boats are among the safest in their class.

All Alunautic Sport boats built by Euro Offshore BV have an anti-slide and self-bailing deck, motorwell (for outboard version) and come standard with anchor compartment including hatch, 2 bollards and hoisting points. The Alunautic Sport boats are



Alunautic Sport boats

The Alunautic Sport boats are available with an in - or outboard type of engine. The inboard version can be equipped with an aft or centre mounted engine, the inboard propulsion options for the Alunautic Sport boats are either sterndrive or waterjet.



Type	Length (m)	Beam (m)	LWL app (m)	Draft (m)	Weight* (kg)	Capacity (kg)	Capacity (p)	Max HP	Classification
Sportboat 4m50	4.62	2.06	3.90	0.3	400	max 950	4 persons (300kg)	40	CE C
Sportboat 5m50	5.69	2.25	4.80	0.3	500	max 1290	6 persons (450kg)	100	CE C
Sportboat 6m50	6.47	2.49	5.80	0.3	650	max 1480	8 persons (600kg)	180	CE C / CE B**
Sportboat 6m50 cabin	6.47	2.49	5.80	0.3	800	max 1480	8 persons (600kg)	180	CE C / CE B**
Sportboat 7-25 meter	Information on request								

* Boat weight is ex engine

** Only in combination with 12cm PU foam filled fender

Standard equipment:

- EOS foam system for extra buoyancy
- Hoisting points
- Anchor compartment incl. hatch
- Bilge outlets
- 1 bollard
- Motorwell for outboard version



Option package

- D-Fender (rubber)
- Steering console
- Steering system (hydraulic/mechanic)
- Cabin
- Leaning post
- Side seats
- Lifting sling
- Boat cover
- Anchor (line)
- Mooring line
- Foam filled fender
- Rubber fender
- Aluminum railing
- Towing pole
- Fire extinguisher
- Professional electrical installation IP67
- Masthead light
- Navigation light
- Horn

Alunautic Work boats

The Alunautic Work boats lines are available in several lengths and custom builds. Our Work boats are made of aluminum with a deep V-hull shape, suitable for inshore shipping. The Work boats are designed with maximum deck space.

Because of their 2 x 2 separate foam filled compartments, these aluminium Work boats are among the safest in their class.

All Alunautic Work boats built by Euro Offshore BV have an anti-slide and self-bailing deck, motorwell and come standard with anchor compartment including hatch, 2 bollards and hoisting points. The Alunautic Work boats are available in lengths of 4.5 meter till 25.00 meter.



Alunautic Work boats

The Alunautic Work boats are available with an in - or outboard type of engine. The inboard version can be equipped with an aft or centre mounted engine, the inboard propulsion options for the Alunautic Work boats are either sterndrive or waterjet.

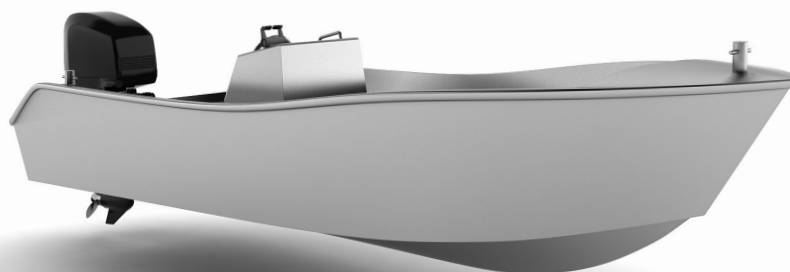

Type	Length (m)	Beam (m)	LWL app (m)	Draft (m)	Weight* (kg)	Capacity (kg)	Capacity (p)	Max HP	Classification
Sportboat 4m50	4.62	2.06	3.90	0.3	400	max 950	4 persons (300kg)	40	CE C
Sportboat 5m50	5.69	2.25	4.80	0.3	500	max 1290	6 persons (450kg)	100	CE C
Sportboat 6m50	6.47	2.49	5.80	0.3	650	max 1480	8 persons (600kg)	180	CE C / CE B**
Sportboat 6m50 cabin	6.47	2.49	5.80	0.3	800	max 1480	8 persons (600kg)	180	CE C / CE B**
Sportboat 7-25	Information on request								

* Boat weight is ex engine

** Only in combination with 12cm PU foam filled fender

Standard equipment:

- EOS foam system for extra buoyancy
- Hoisting points
- Anchor compartment incl. hatch
- Bilge outlets
- 1 bollard
- Maximum work deck available



Option package

- D-Fender (rubber)
- Steering console
- Steering system (hydraulic/mechanic)
- Cabin
- Leaning post
- Side seats
- Lifting sling
- Boat cover
- Anchor (line)
- Mooring line
- Foam filled fender
- Rubber fender
- Aluminum railing
- Towing pole
- Fire extinguisher
- Professional electrical installation IP67
- Masthead light
- Navigation light
- Horn

Alunautic MPRV

Multi Purpose Re-attachable Vessel



Alunautic MPRV

The Alunautic MPRV (Multi Purpose Re-attachable Vessel) is a new modular concept in boat building by Euro Offshore BV.

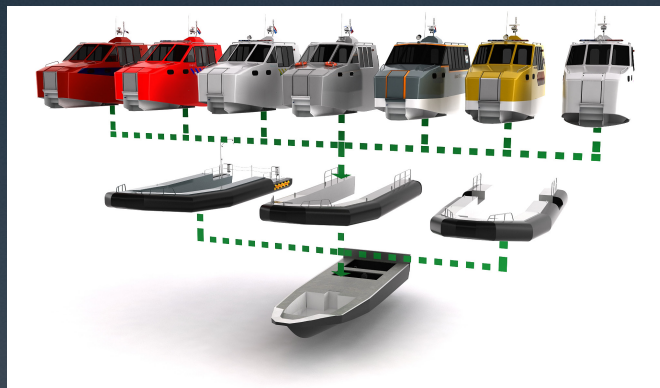

The client can choose between several cabins and fender types, this makes the boat suitable for almost any purpose. The cabin can vary in length and the interior and deck layout are fully custom.



The MPRV can be used for projects worldwide due to the re-attachable cabin. The hull and cabin are shipped around the world in 2 standard open top containers.



The advantages of the Alunautic MPRV

- Freedom in design (Length cabin, interior layout, choice of engines, finishing)
- Suitable for multi purposes
- One hull, different cabins, also at a later stage
- Re-attachable cabin provides the option for worldwide shipping
- Lloyds approved construction design





E0 Lifecycle program

With the E0 lifecycle program we provide a one stop solution for our clients:

Service - repair - sales - commissioning

Our program starts with service. We service under the name Euro Offshore Services BV. Our full range of services:

- Commissioning of Alunautic boats on location.
- Survey on boats.
- Maintenance and repairs.
- Genuine spare parts supply.
- Instruction and training programs of customers during service work on above mentioned products.

Constant technical assistance and immediate availability of skilled experts are only some of our strengths.

We ensure the availability of our service engineers all over the world.



Worldwide lifecycle program

Service - repair - sales - commissioning

Professional Offshore Accessoires

Euro Offshore B.V. has developed a state of the art accessories range for their professional offshore patrol and rescue boats.



The accessories have proven themselves by the intensive use and testing in the boat brands Blue-Spirit, Alunautic and FibreShark.



At Euro Offshore B.V. we would like to share our experience and made our exclusive accessories range available for public.





Professional Offshore Accessories

- Jockeyseats
- Leaning posts
- Steering consoles
- T-Tops
- Rollbars

Jockeysseats



50-60 mm suspended jockeysseat

The standard jockeysseat has a suspension of approximately 50 till 60 mm.

The jockeysseat has proven itself since the beginning of the Alunautic boats.

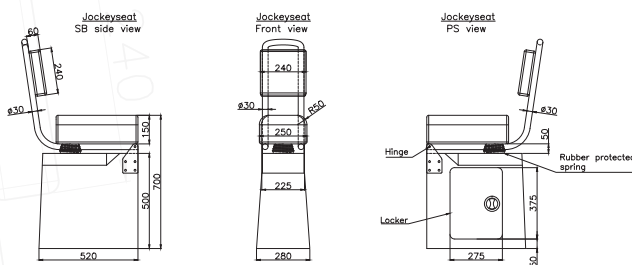

The pdf or autocad drawing is available for measurements or to integrate our jockeysseat in your design.



Base of the seat is made with vacuum injection to reduce weight and is available in any colour.

150 mm suspended jockeysseat

New in our accessoires range is the extra suspended jockeysseat. With adjustable gas suspension from the well known brand 'Hyperpro'. Famous for their use in racing and other high end applications.

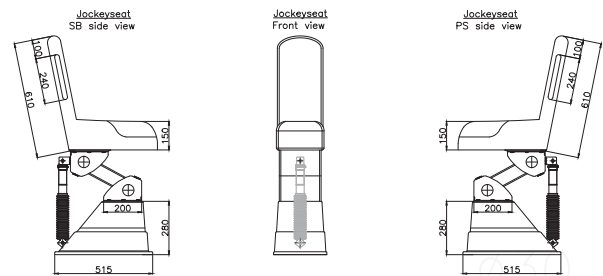

The pdf or autocad drawing is available for measurements or to integrate our jockeysseat in your design.



- Optional gas adjustable suspension.
- Optional adapter for 10 cm height elevation.
- Optional rail sliding system for jockeysseat mounting.

Aluminium leaning post



Aluminium leaning posts

This aluminium leaning post is available in custom dimensions as requested. The aluminium frame is standard painted in a black colour, custom colours on request.

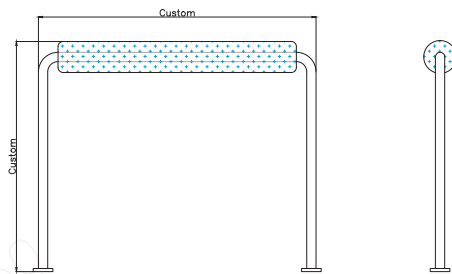

The pdf or autocad drawing is available for measurements or to integrate our aluminium leaning post in your design.



Aluminium leaning posts

This aluminium leaning post is available in custom dimensions as requested. The aluminium frame is standard painted in a black colour, custom colours on request.

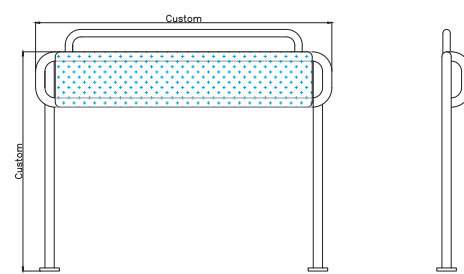

The pdf or autocad drawing is available for measurements or to integrate our aluminium leaning post in your design.



GRP steering consoles

Steering console



GRP steering console small

This GRP steering console can be used for all boats. The l x b x h dimensions of the console are 1050 x 950 x 1600 mm.

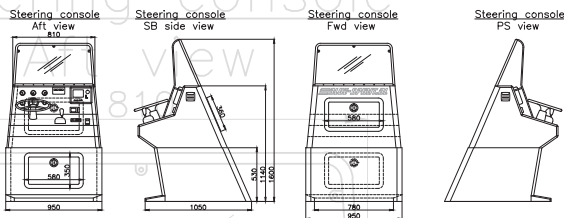

GRP steering console wide with door

This GRP steering console can be used for all boats. The l x b x h dimensions of the console are 1125 x 1120 x 1600 mm.

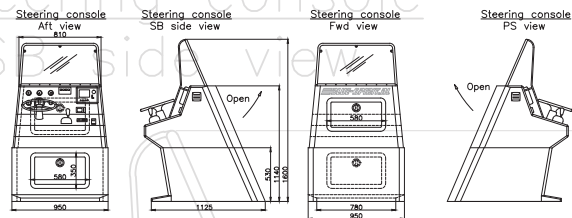

GRP steering console with engine box

This GRP steering console can be used for all boats. The l x b x h dimensions of the console are 1295 x 950 x 1600 mm.

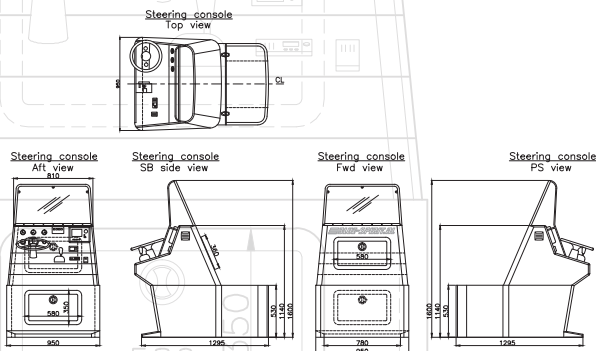

All GRP consoles are standard made by the hand lay-up process. On request with vacuum injection and diviny cell core. Colour on request.

GRP steering console with toilet

This GRP steering console can be used for all boats, optional with toilet under the seat. The l x b x h dimensions of the console are: 1295 x 1120 x 1600 mm.

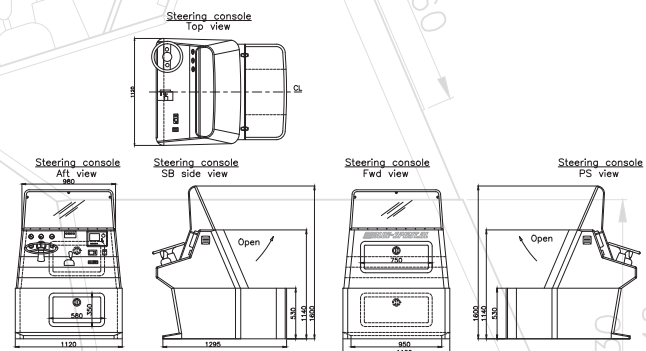

All GRP consoles are standard made by the hand lay-up process. On request with vacuum injection and diviny cell core. Colour on request.

Aluminium steering console



Aluminium steering console small

This aluminium steering console can be used on all boats. The l x b x h dimensions of the console are 570 x 1000 x 1130 mm.

Steering console

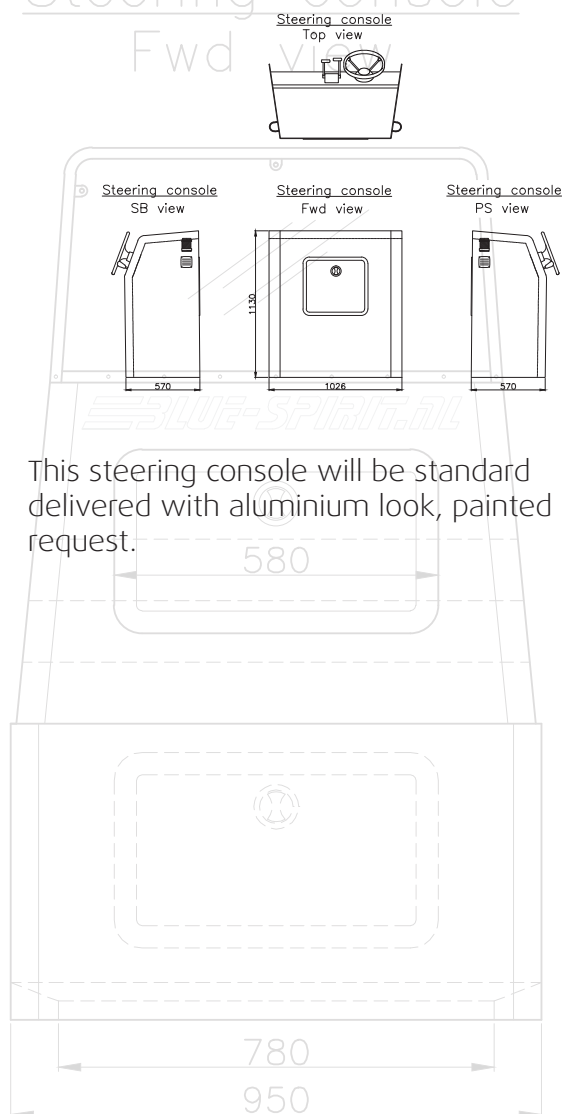

This steering console will be standard delivered with aluminium look, painted on request.

Aluminium steering console extra wide

This aluminium steering console can be used on all boats. The l x b x h dimensions of the console are 680 x 1250 x 1545 mm.

Steering console

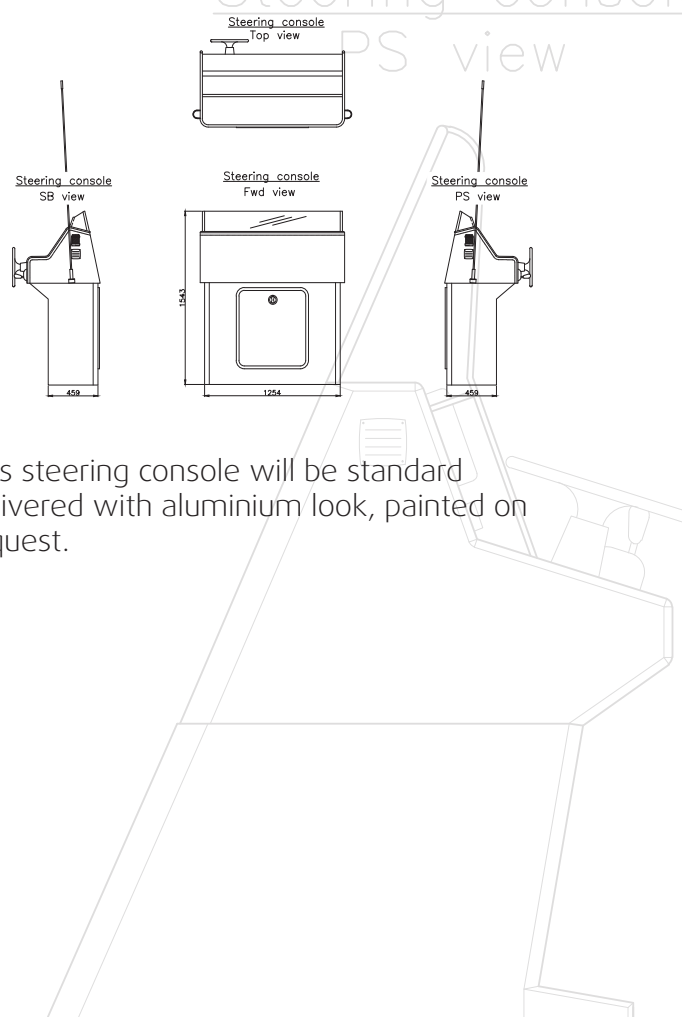

This steering console will be standard delivered with aluminium look, painted on request.

Aluminium T-Tops



T-Top with canvas roof

Aluminium T-Top with canvas roof. Frame standard delivered in black paint, custom colour on request. Canvas colour on request.

The pdf or autocad drawing is available for standard dimensions or to integrate our T-Top in your design.

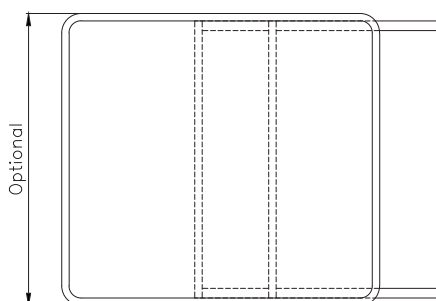
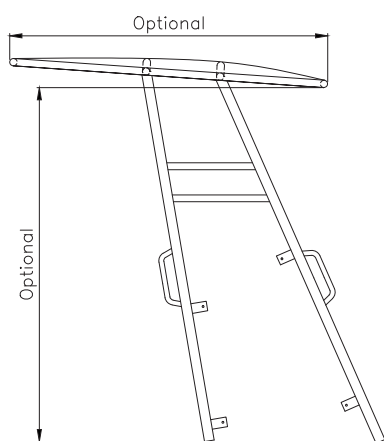

T-Top with GRP roof

Aluminium T-Top with GRP or aluminium roof. Frame standard delivered in black paint, custom colour on request. GRP / aluminium colour on request.

The pdf or autocad drawing is available for standard dimensions or to integrate our T-Top in your design.

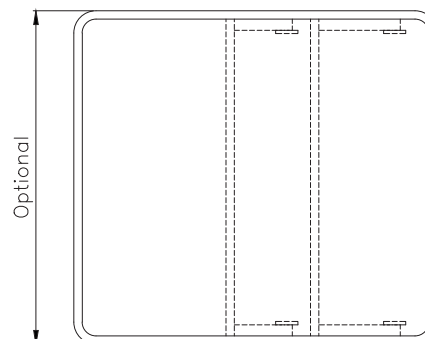
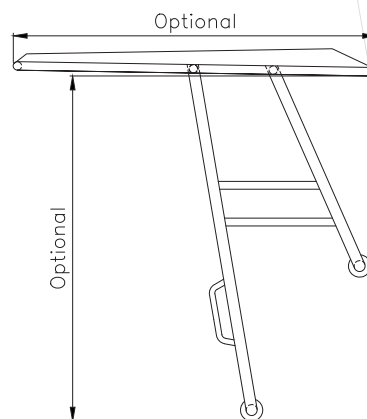

Aluminium rollbars



Aluminium rollbar small

Available in aluminium or painted. 2D pdf and autocad drawings available.

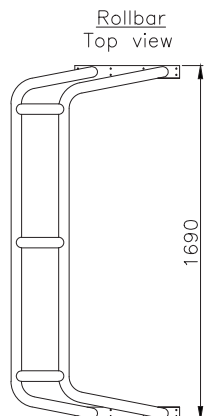
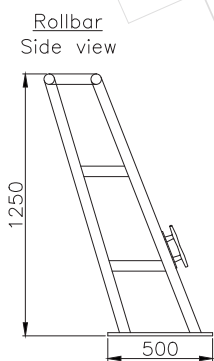

Aluminium rollbar large

Available in aluminium or painted. 2D pdf and autocad drawings available.

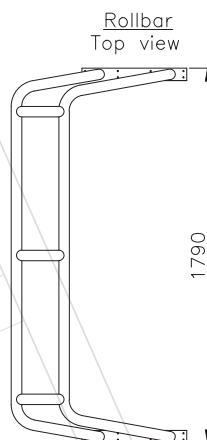
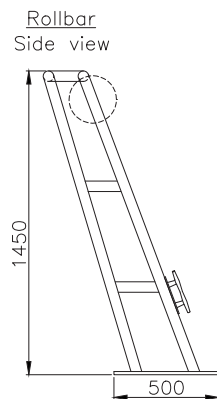

Selfrighting rollbar

This aluminium rollbar is equipped with a selfrighting sytem made of a hypalon bag with CO2 filling system. The bag volume varies per boat type.

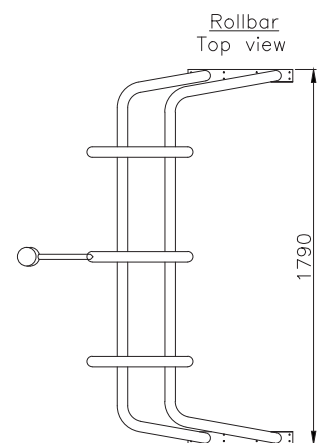
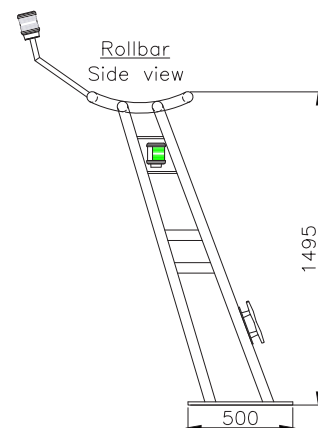





Engines

Alunautic can supply in - and outboard engines and parts of the following manufacturers:

- Mercury
- Yanmar
- Marine Diesel
- Steyr
- Bukh
- Volvo
- Yamaha
- Evinrude

We can advise on the best possible engine for your application. If you are looking for the right package for your purpose, contact us for advice. Most conventional parts are in stock or in stock at our suppliers.



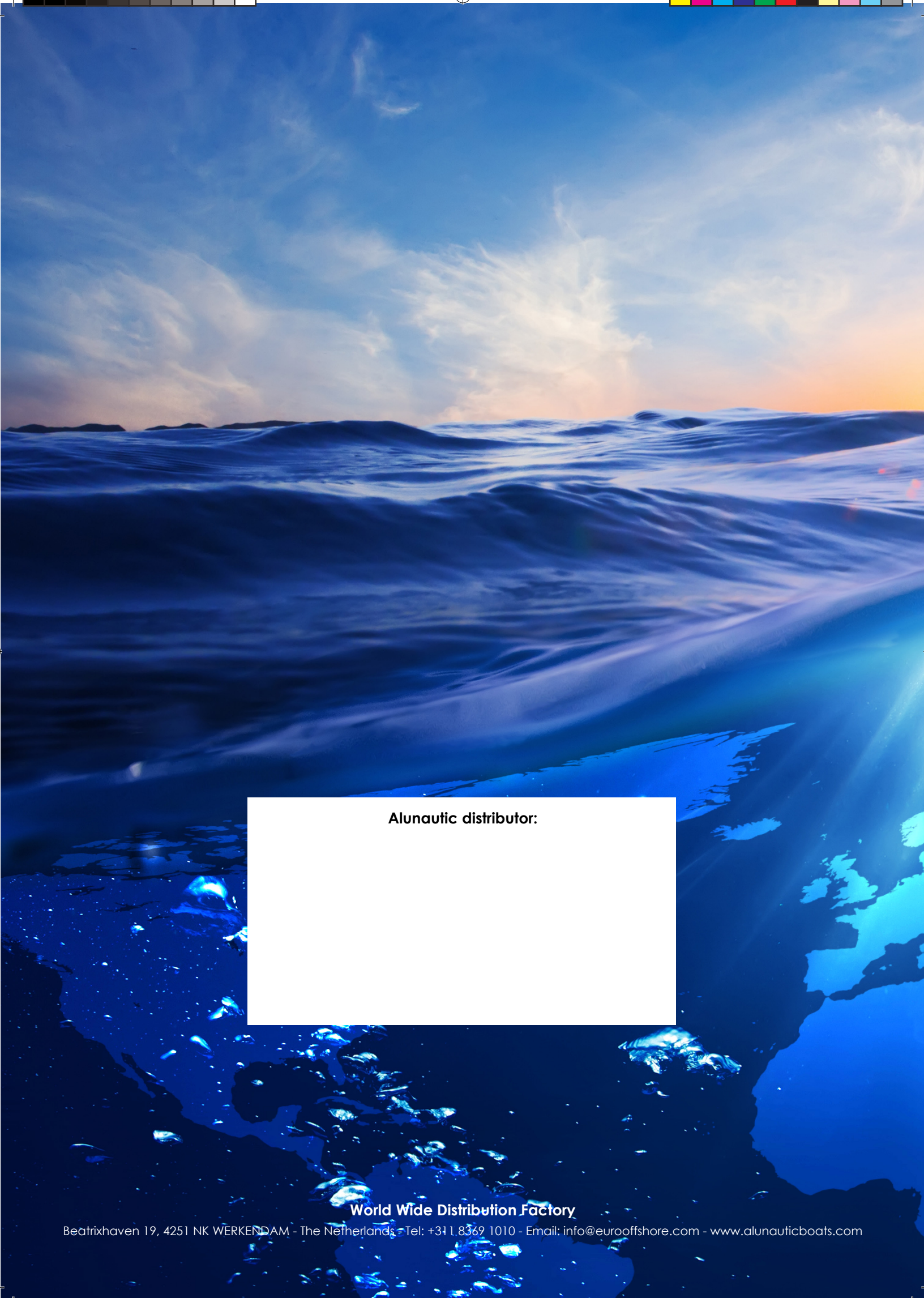

Alunautic distributor:

World Wide Distribution Factory

Beatrixhaven 19, 4251 NK WERKENDAM - The Netherlands - Tel: +31 1.8369 1010 - Email: info@eurooffshore.com - www.alunauticboats.com

